

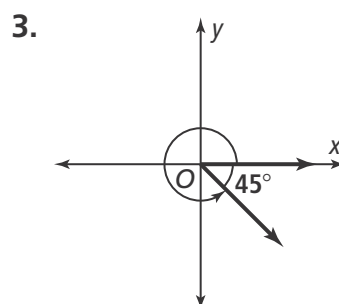

7-2 Additional Practice

Angles and the Unit Circle

Find the measure of each angle as a positive angle measure, a negative angle measure, and an angle measure that is greater than 360° .

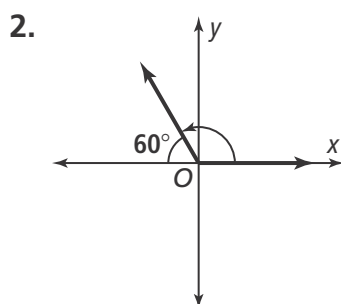
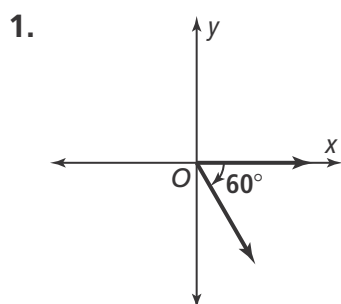

Sketch each angle in standard position.

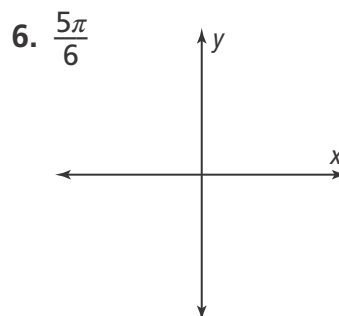
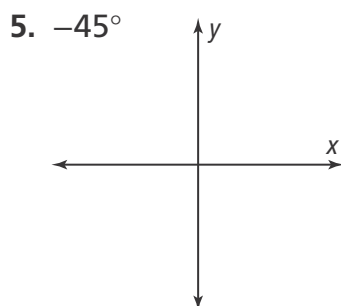
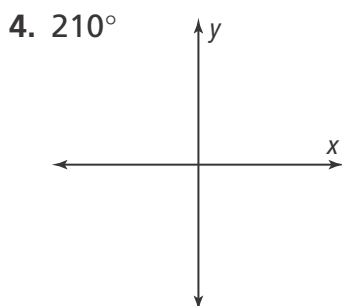

Find the measure of an angle in standard position for each reference angle.

7. 10° in Quadrant II

8. 35° in Quadrant IV

9. 34° in Quadrant III

Convert each angle to degrees.

10. $\frac{3\pi}{2} =$ _____ degrees 11. $-\frac{6\pi}{5} =$ _____ degrees 12. $\frac{7\pi}{4} =$ _____ degrees

Convert each angle to radians.

13. 140° degrees = _____ 14. -160° degrees = _____ 15. 330° degrees = _____

16. A Ferris wheel rotates $\frac{9\pi}{8}$ radians prior to making a stop. The total height of the Ferris wheel is 246 ft. How far around did the Ferris wheel travel? Round to the nearest whole foot.

17. How does the formula for the circumference of a circle relate to one rotation around the unit circle?



7-2 Additional Practice

Angles and the Unit Circle

Find the measure of each angle as a positive angle measure, a negative angle measure, and an angle measure that is greater than 360° .

1.

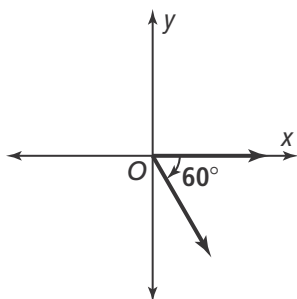

$300^\circ, -60^\circ, 660^\circ$

2.

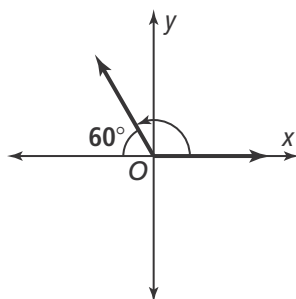

$120^\circ, -240^\circ, 480^\circ$

3.

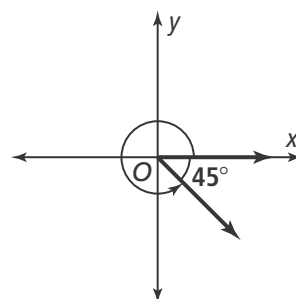

$315^\circ, -45^\circ, 675^\circ$

Sketch each angle in standard position.

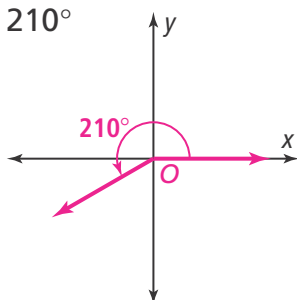
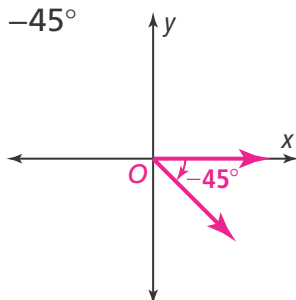
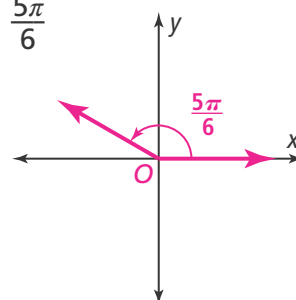
4. 210° 5. -45° 6. $\frac{5\pi}{6}$ 

Find the measure of an angle in standard position for each reference angle.

7. 10° in Quadrant II 170° 8. 35° in Quadrant IV 325° 9. 34° in Quadrant III 214°

Convert each angle to degrees.

10. $\frac{3\pi}{2} = 270^\circ$ degrees 11. $-\frac{6\pi}{5} = 144^\circ$ degrees 12. $\frac{7\pi}{4} = 315^\circ$ degrees

Convert each angle to radians.

13. 140° degrees = $\frac{7\pi}{9}$ 14. -160° degrees = $-\frac{8\pi}{9}$ 15. 330° degrees = $\frac{11\pi}{6}$

16. A Ferris wheel rotates $\frac{9\pi}{8}$ radians prior to making a stop. The total height of the Ferris wheel is 246 ft. How far around did the Ferris wheel travel? Round to the nearest whole foot. **435 ft**

17. How does the formula for the circumference of a circle relate to one rotation around the unit circle?

You multiply the radius of a circle by 2π to find its circumference. One rotation around the unit circle is 2π radians.